

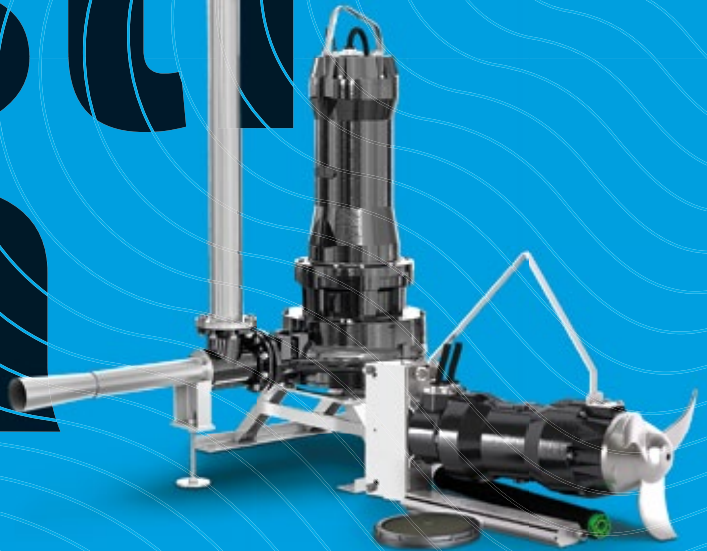

A Tsurumi Pump Company

Industrial Wastewater Treatment Plants



PREMIUM SOLUTIONS FOR INDUSTRIAL
WASTEWATER TREATMENT PLANTS

SUBMERSIBLE ELECTRIC PUMPS • AERATION AND MIXING • LIFTING STATIONS

zenit.com

Premium solutions for industrial wastewater treatment plants.

In over **sixty years of history**, we have developed cross-functional skills to support you in the selection, installation and use of submersible pumps and water treatment systems.

Submersible electric pumps, lifting stations, submersible mixers, wastewater treatment plants systems.

Different solutions with a single manufacturing philosophy and **tailored to the customer's needs** to better suit the many scenarios of **industrial applications**.

High-efficiency motors, modular hydraulics optimized on working points, and metal alloys **specific** to the type of liquid to be treated.



TREATMENT PLANTS



SHIPYARDS



FOOD PROCESSING PLANTS



MANUFACTURING INDUSTRY



CHEMICAL/PETROCHEMICAL SECTOR



BIOGAS INSTALLATIONS

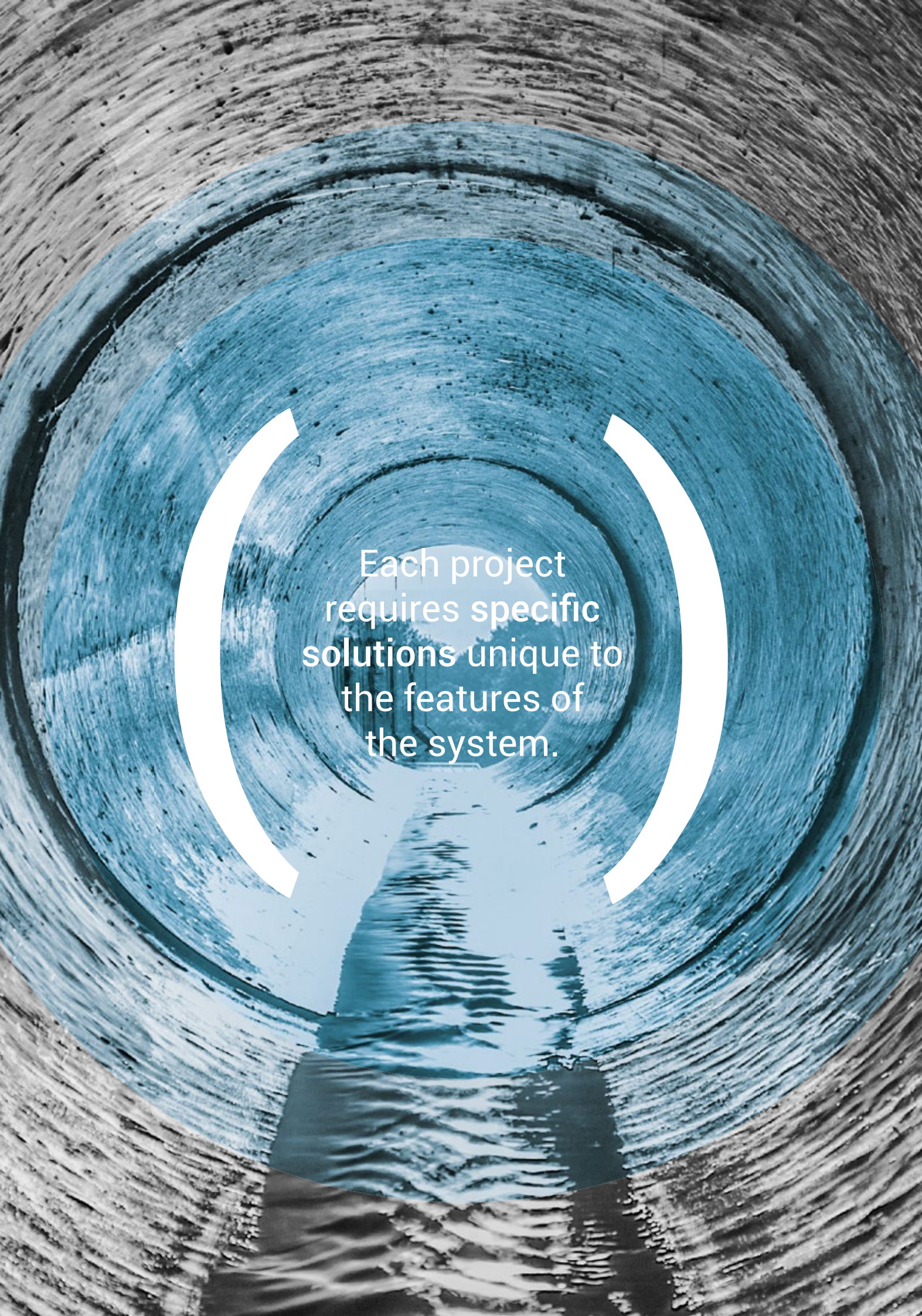

Each project
requires specific
solutions unique to
the features of
the system.

LIFTING AND RAIS

liftBOX

Polyethylene Lifting Stations

650 - 19000 L
DN50 - DN150
BURIED INSTALLATION

The **liftBOX** lifting stations are intended for the collection and release of wastewater or rainwater. They consist of a polyethylene tank and an internal pumping system controlled by floats or level probes and an electrical control panel.

They can be equipped with pre-assembled valve operating chamber separate from the effluent collection compartment to allow easy, hygienic and safe maintenance operations.

liftBOX lifting stations, designed for buried installation, have a volume of between 1,000 and 19,000 litres and can be connected to systems with outlet pipes from DN50 to DN150.

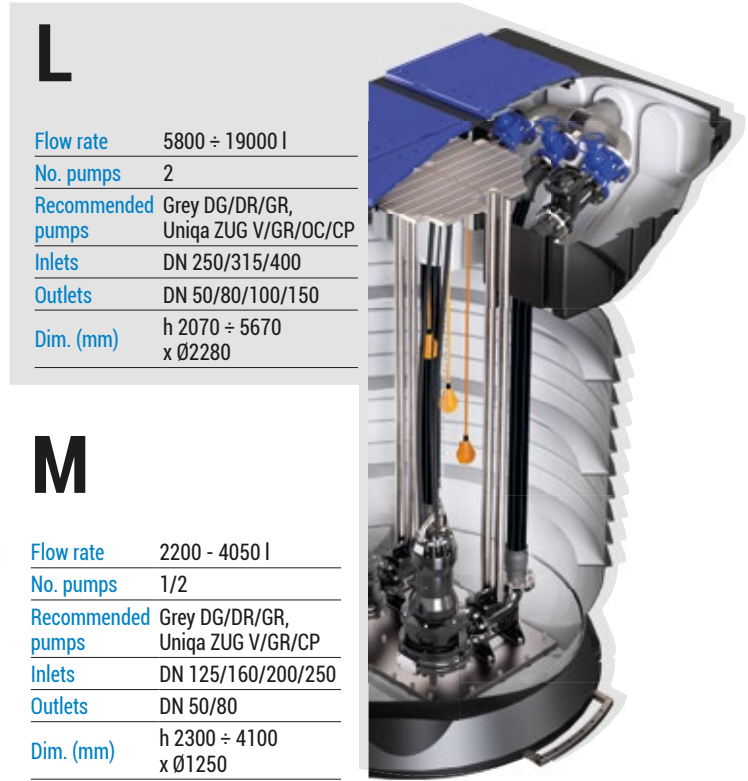

L

Flow rate	5800 ÷ 19000 l
No. pumps	2
Recommended pumps	Grey DG/DR/GR, Uniqa ZUG V/GR/OC/CP
Inlets	DN 250/315/400
Outlets	DN 50/80/100/150
Dim. (mm)	h 2070 ÷ 5670 x Ø2280

S



Flow rate	650 ÷ 1450 l
No. pumps	1/2
Recommended pumps	Grey DG/GR, DGO, DGE, GRBluePRO
Inlets	DN 125/160
Outlets	DN 50
Dim. (mm)	h 1200 ÷ 2300 x Ø1000



M

Flow rate	2200 - 4050 l
No. pumps	1/2
Recommended pumps	Grey DG/DR/GR, Uniqa ZUG V/GR/CP
Inlets	DN 125/160/200/250
Outlets	DN 50/80
Dim. (mm)	h 2300 ÷ 4100 x Ø1250

AGGRESSIVE BRACKISH ACIDIC WATERS

The "Special Alloys" pump series share an oil-bath motor with thermal protections and a double mechanical seal, cooled by motor oil, for continuous use even under severe conditions. The **DRX**, **DRY** and **DGX** models, made of CF8_M [AISI 316] stainless steel, are particularly suitable in the presence of corrosive and aggressive liquids in industrial applications in the chemical and pharmaceutical fields or in the presence of marine waters. The **DRB** and **DGB** models, on the other hand, made of bronze-aluminium, are ideal in seawater or brackish liquids and are widely used in the fish and livestock sectors.

DGX



Power	0.37 - 1.5 kW
Poles	2/4
Outlet	2" V DN65 - DN80 H
Free Passage	max 60 mm
Max Flow Rate	18.4 l/s
Head Max	13.7 m
Impeller	Vortex

DRX



Power	0.37 - 1.5 kW
Poles	2
Outlet	1¼" - 2" V -
Free Passage	max 15 mm
Max Flow Rate	12.5 l/s
Head Max	17.3 m
Impeller	Open multichannel

DRY



Power	2.4 - 15 kW
Poles	2/4
Outlet	DN65 - DN100 H -
Free Passage	max 80 mm
Max Flow Rate	72.8 l/s
Head Max	38.3 m
Impeller	Open multichannel

DRB



Power	0.37 - 1.5 kW
Poles	2
Outlet	1¼" - 2" V -
Free Passage	max 15 mm
Max Flow Rate	12.5 l/s
Head Max	17.5 m
Impeller	Open multichannel

DGB



Power	0.37 - 1.5 kW
Poles	2
Outlet	2" V -
Free Passage	38 mm
Max Flow Rate	10.6 l/s
Head Max	13.9 m
Impeller	Vortex

SING WASTEWATER AN

Grey

series

Submersible Electric Pumps for Drainage and Lifting

0.55 - 18.5 kW
50/60 Hz

The Grey series was born in 2018, integrating the legacy and knowledge accumulated by the Zenit Group over sixty years of designing and manufacturing submersible electric pumps: cutting-edge technical solutions, efficient motors, and completely redesigned hydraulics to deliver high performance. The Grey project is based on a complete redesign and modernisation of hydraulics and motors to ensure high performance, low fuel consumption, high reliability and exceptional versatility. The range is available in four hydraulic variants, offered according to the type of application: Vortex, Channels, Grinder and High Head.

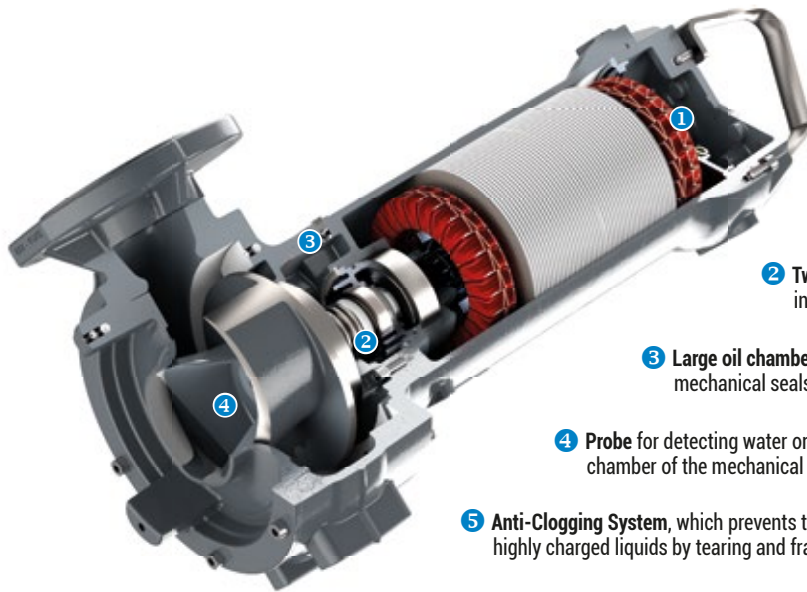

CE Ex db h IIB T4 Gb
2460 II 2G

- 1 Drive shaft made of AISI 431 stainless steel
Impeller coupling by conical coupling.
- 2 Two mechanical seals in silicon carbide (SiC-SiC)
inside the oil chamber.
- 3 Large oil chamber ensuring long life of
mechanical seals
- 4 Probe for detecting water or moisture inside the oil
chamber of the mechanical seals.
- 5 Anti-Clogging System, which prevents the impeller from blocking even under
highly charged liquids by tearing and fraying filamentous bodies.



DGG

Power	0.55 - 15 kW
Poles	2/4
Outlet	1½" - 2½" V 2" DN32 - DN150 H
Free Passage	max 125mm
Max Flow Rate	105.6 l/s
Head Max	24.5 m
Impeller	Vortex



DRG

Power	0.55 - 18.5 kW
Poles	2/4/6
Outlet	1½" - 2½" V 2" DN32 - DN250 H
Free Passage	max 100x70mm
Max Flow Rate	205.3 l/s
Head Max	50 m
Impeller	Channels



GRG

Power	1.1 - 7.5 kW
Poles	2
Outlet	- 1½" DN32 H 2" DN50 H
Free Passage	-
Max Flow Rate	8.4 l/s
Head Max	53.3 m
Impeller	Open multichannel with grinding system



APG

Power	1.1 - 7.5 kW
Poles	2
Outlet	- 1½" DN32 H 2" DN50 H
Free Passage	max 10 mm
Max Flow Rate	10.5 l/s
Head Max	51.9 m
Impeller	High head

UNIQA® High Efficiency Submersible Electric Pumps

1.1 - 355 kW
HIGH EFFICIENCY
50/60 Hz

The UNIQA series is developed to offer high performance and low energy/environmental impact. Premium efficiency class IE3 motors, coupled with hydraulics characterized by high performance optimized at the point of operation, ensure the best performance through reduced energy consumption. UNIQA is Zenit's range of electric pumps designed for industrial and heavy-duty applications in civil and industrial sewage treatment plants, sewer lifts and conveying effluent containing solids. The series offers five types of hydraulics to suit every application: Vortex, Channels, Chopper, Grinder and High Head.

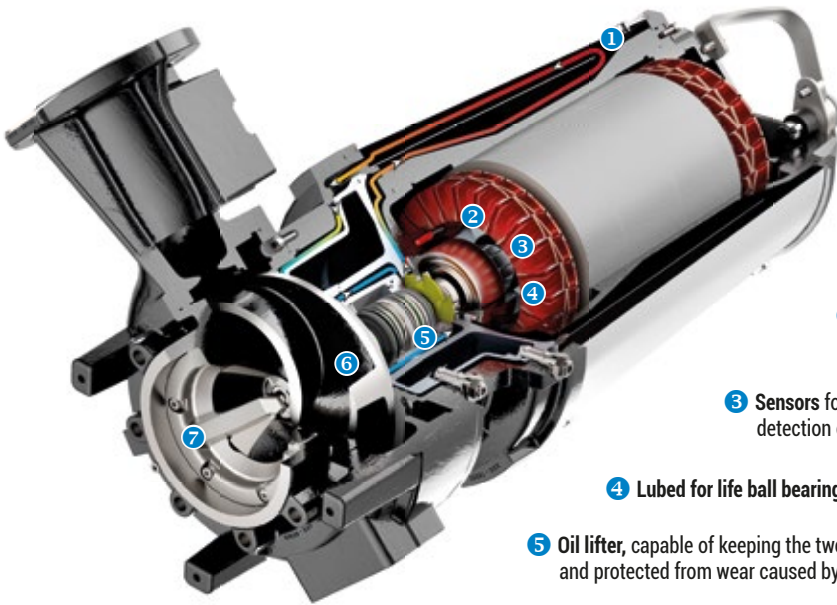

WET | DRY
 CE Ex db h IIB T4 Gb | CE Ex db h IIB T4 Gb
 2460 II 2G | 2460 II 2GD
 Ex h tb IIIC T135°C Db

- 1 DRY models with double stainless steel liners. The engine is cooled by the special mixture of biodegradable glycol and water circulating in the unique closed circuit. **Service S1** guaranteed even in dry installations, partially submerged conditions or high temperature environments.
- 2 Probe for detecting water or moisture inside the oil chamber of the mechanical seals.
- 3 Sensors for monitoring temperature, abnormal impeller vibration, bearing overheating, or detection of water or moisture seepage into the motor and terminal compartment.
- 4 Lubed for life ball bearings sized to guarantee 100,000 hours of operation.
- 5 Oil lifter, capable of keeping the two silicon carbide mechanical seals always lubricated and protected from wear caused by friction.
- 6 Anti-Clogging System, which prevents the impeller from blocking even under highly charged liquids by tearing and fraying filamentous bodies.



- 7 Hydraulic "Chopper," capable of cutting and expelling any shreddable solid body present in the effluent. The heart of the system is the strong steel knife, shaving with the blades from the sharp edge of the channel impeller made of hard cast iron [hardness value 450-500 HB].



ZUGCP

Power	1.5 - 75 kW
Poles	2/4/6
Outlet	-
	DN80 - DN200
Free Passage	max 80 mm
Max Flow Rate	283.0 l/s
Head Max	83.0 m
Impeller	Chopper in hard cast iron



ZUGGV

Power	1.1 - 37 kW
Poles	2/4/6
Outlet	-
	DN65 - DN150 H
Free Passage	max 150 mm
Max Flow Rate	116.0 l/s
Head Max	79.5 m
Impeller	Vortex



ZUGOC

Power	1.1 - 355 kW
Poles	2/4/6/8
Outlet	-
	DN65 - DN500 H
Free Passage	max 160 x 110 mm
Max Flow Rate	1240.0 l/s
Head Max	100.0 m
Impeller	Channels with ACS+ABS



ZUGHP

Power	4 - 15 kW
Poles	2
Outlet	-
	DN50 - 2" H
Free Passage	max 7.5 mm
Max Flow Rate	11.8 l/s
Head Max	64.9 m
Impeller	High head



ZUGGR

Power	4 - 11 kW
Poles	2
Outlet	-
	DN50 - 2" H
Free Passage	-
Max Flow Rate	9 l/s
Head Max	64 m
Impeller	Open multichannel with grinding sys

Mixer ZM High Efficiency Submersible Mixers

0.75 - 7.5 kW
HIGH EFFICIENCY
50/60 Hz

The ZM Mixer range has been designed on a modular basis: high-efficiency motors derived from the UNIQA series are coupled to propellers of different shapes, sizes and materials. This ensures a high degree of versatility that makes them suitable for any type of application and allows for low operating, energy, and maintenance costs. In heavy-duty applications and in particularly aggressive process waters, ZM Mixers can be supplied with stainless steel, and the propellers with Duplex/Vulkollan coating, in addition to special protective coatings.

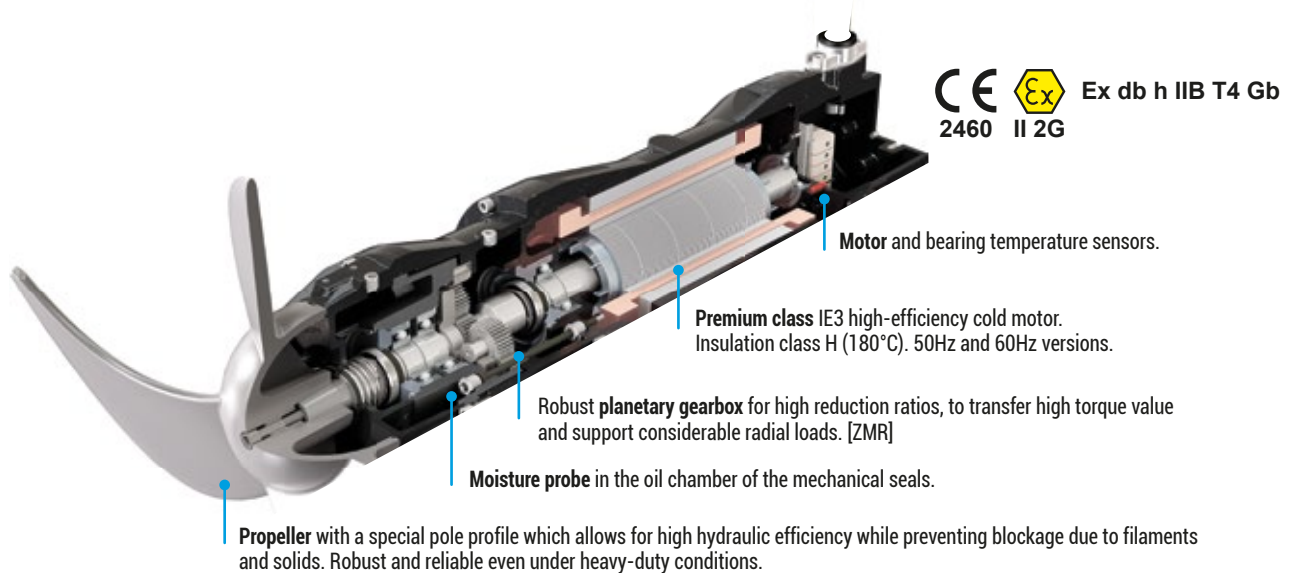

ZMD

Structure	Cast Iron EN-GJL250
Motors	0.75 - 4.5 kW - 4/6/8 poles
Propeller	1450/960/750 rpm Stainless steel Ø200 - Ø400
Transmission	Direct
Thrust	155 - 1060 N

ZMR

Structure	Cast Iron EN-GJL250
Motors	3 - 7.5 kW - 4/6 poles
Propeller	177 - 300 rpm Stainless steel Ø650
Transmission	With geared motor
Thrust	800 - 2100 N

ZMXD

Structure	Stainless steel
Motors	0.75 / 1.1 kW - 4 poles
Propeller	1396 / 1380 rpm Stainless steel Ø200
Transmission	Direct
Thrust	155 - 210 N

AERATION

OXYPLATE 9/12"

Outer diameter	270/340 mm
Min. operating flow rate	2 Nm ³ /h
Max. operating flow rate	6/10 Nm ³ /h
Flow rate limit	10/15 Nm ³ /h
Active surface area	0.038/0.06 m ²
Membrane thickness	2 ± 0.15 mm

OXYINOX L305/L610

Body material	Stainless steel
Diameter of upper/lower holes	4/8 mm
Threaded connection	3/4" NP ^T
Nominal flow rate	20.0/40.0 Nm ³ /h
Min operating flow rate	3.5/7.0 Nm ³ /h
Max operating flow rate	40/80 Nm ³ /h

OXYTUBE

Outer diameter	63 mm
Length of perforations	500/750/1000 mm
Min operating flow rate	1/2/3 Nm ³ /h
Max operating flow rate	6/9/12 Nm ³ /h
Flow rate limit	10/15/20 Nm ³ /h
Active surface area	0.09/0.135/0.18 m ²
Membrane thickness	1.7 ± 0.2 mm

JETOXY

Body	GJL-250
Jetoxy 50 Diffuser cone	GJL-250
Hardware	Stainless steel
Body	Cast Iron GJL-250
Jetoxy 80 - 300 Diffuser cone	Stainless steel - AISI 304
Membrane	Vulkollan
Hardware	Stainless steel

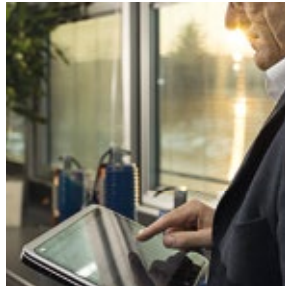

A  TSURUMI PUMP COMPANY



For more information, visit www.zenit.com

The data provided is not binding. **Zenit** reserves the right to make changes to the product without prior notice. This catalogue can be downloaded as a digital version from: www.zenit.com

Code 290400172
Rev. 1 - 09/2024